

Classes of heavy vehicles in the Heavy Vehicle National Law

The Heavy Vehicle National Law (HVNL) provides for **three classes** of heavy vehicle as a means of managing the different access requirements of different types of heavy vehicles. Some, but not all, jurisdictions had similar classes under previous legislation.

Vehicle classes will appear on legal documents such as permits and notices, and while beneficial, it is not necessary for operators to remember or know what class of vehicle they operate. Common terminology describing heavy vehicles, such as B-doubles and mobile cranes, will continue to be used by the National Heavy Vehicle Regulator (NHVR).

This fact sheet illustrates some common examples from the three different classes of heavy vehicles and is provided for guidance only. For further information, please contact the NHVR.

Class I heavy vehicles

Special purpose vehicles

A special purpose vehicle is a motor vehicle or trailer, other than an agricultural vehicle or a tow truck, built for a purpose other than carrying goods, or a concrete pump or fire truck (both of which carry water). Examples of a special purpose vehicle include a mobile crane, a concrete pump, drill rig or fire truck. Special purpose vehicles are considered class 1 heavy vehicles when they do not comply with a prescribed mass or dimension requirement applying to it (HVNL s116 (1) (a)).



↑Figure 1: Truck-mounted drilling rig

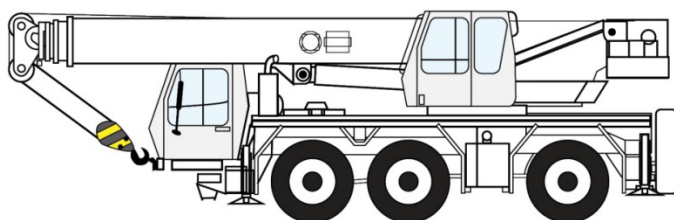

↑Figure 2: 3-axle all-terrain crane

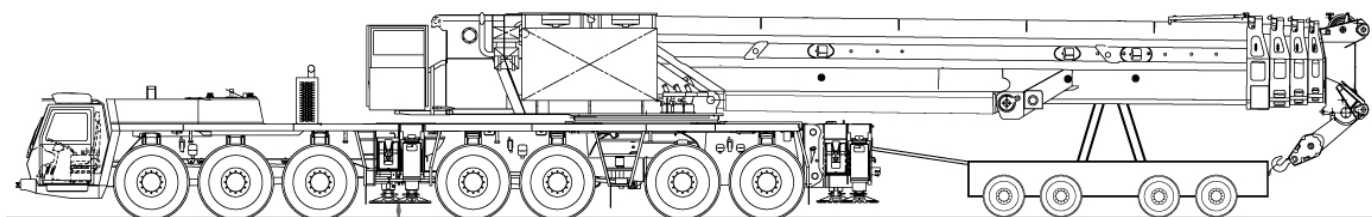

↑Figure 3: 7-axle all-terrain crane with boom supported on 4-axle dolly

Agricultural vehicles, implements and trailers

An agricultural vehicle is considered a class 1 restricted access heavy vehicle if it, together with its load, does not comply with a prescribed mass or dimension requirement (HVNL s116 (1) (b)). Examples of an agricultural vehicle include harvesters and tractors. Any agricultural trailer is considered a class 1 heavy vehicle, for example augers, comb trailers and conveyors (HVNL s116 (2)).

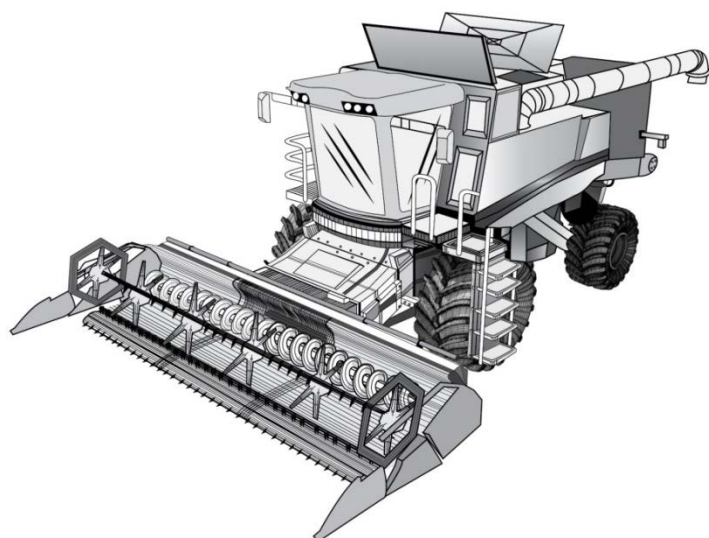

↑Figure 4: Combine harvester



↑Figure 5: Grain auger



↑Figure 6: Comb trailer

Oversize/overmass vehicles

An oversize or overmass vehicle is a heavy vehicle or combination which alone, or together with its load, exceeds prescribed mass or dimension requirements, and is a heavy vehicle carrying, or designed for the purpose of carrying, a large indivisible item (HVNL s116 (1) (c)). This does not include road trains or B-doubles, or vehicles carrying a freight container designed for multi-modal transport. Examples include a prime mover and extendable trailer or a prime mover and low loader combination.

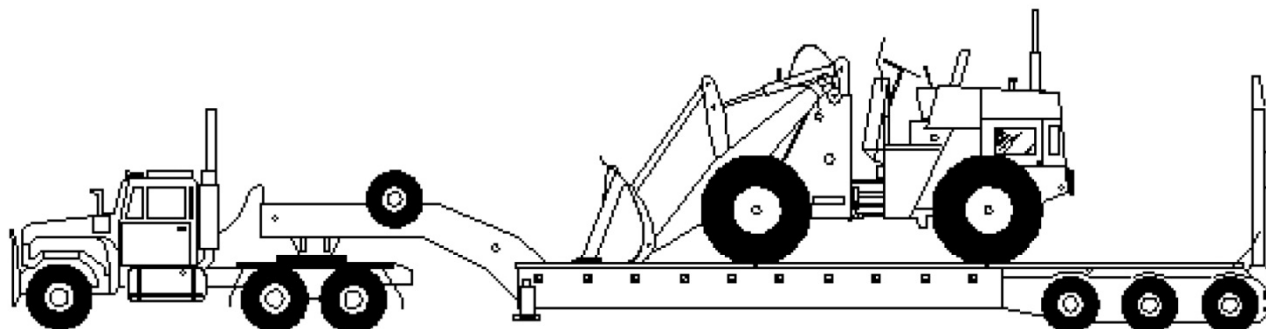

↑Figure 7: Prime mover and tri-axle low loader combination

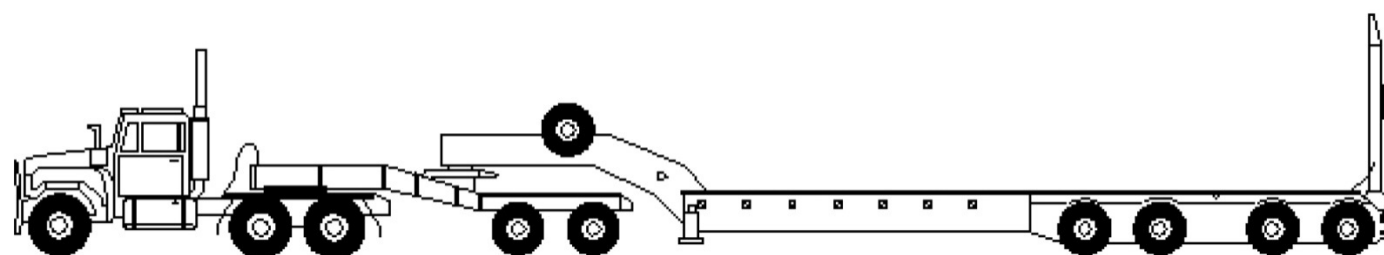

↑Figure 8: Prime mover and spread quad-axle low loader with 2-axle gooseneck dolly

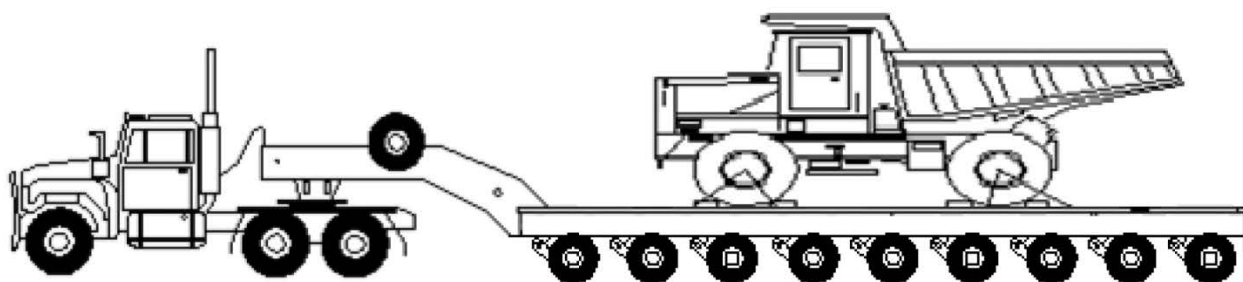

↑Figure 9: Prime mover and platform trailer with 9 axles

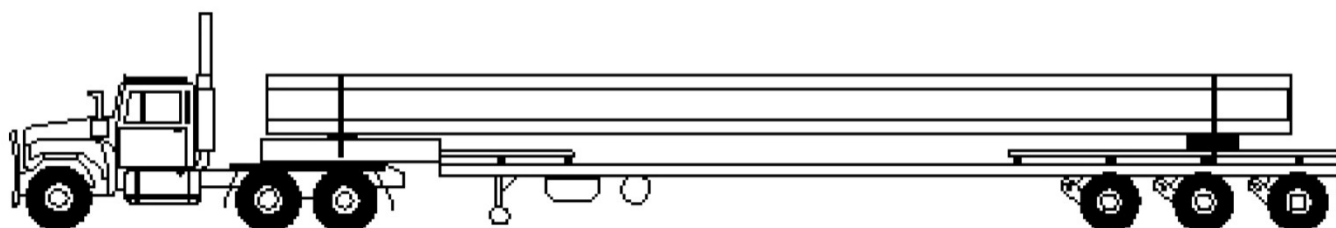

↑Figure 10: Prime mover and extendable trailer

Class 2 heavy vehicles

Freight-carrying vehicles

General freight carrying vehicles that are longer than 19m require specific networks that are capable of handling these larger vehicles. This is usually managed by declaring route networks in gazette notices, but where a network does not exist, an operator may apply for a permit. There are a number of common class 2 heavy vehicle combinations.

A B-double is a class 2 heavy vehicle (HVNL s136 (a) (ii) (A)) that consists of a prime mover towing two semitrailers, with the first semitrailer being attached directly to the prime mover by a fifth wheel coupling and the second semitrailer being mounted on the rear of the first semitrailer by a fifth wheel coupling on the first semitrailer. A B-double must comply with prescribed mass and dimension requirements.

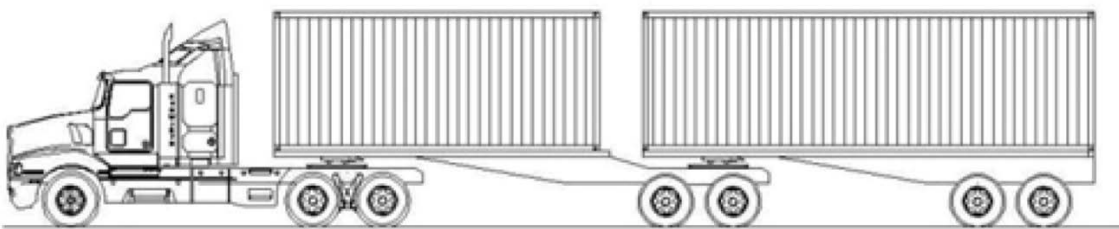

↑Figure I1: Typical 7-axle B-double (other axle combinations are possible)

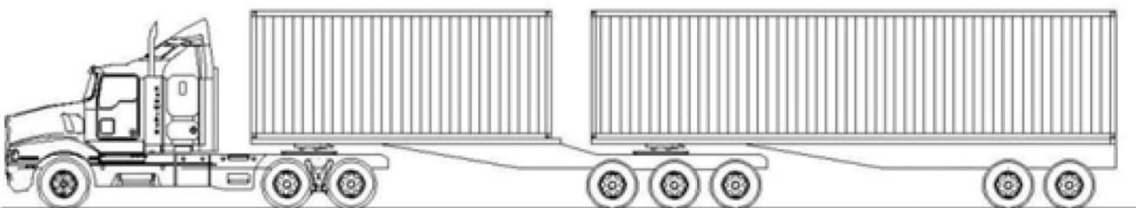

↑Figure I2: Typical 8-axle B-double (other axle combinations are possible)

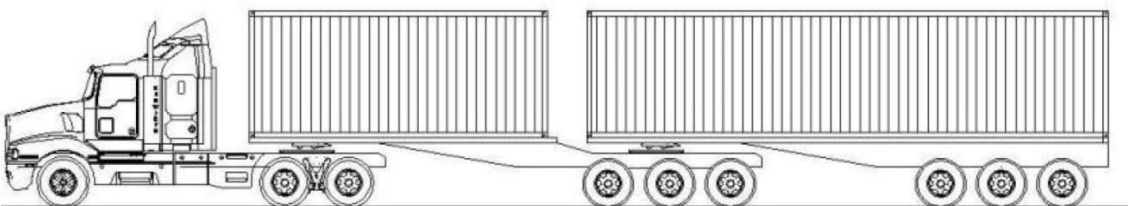

↑Figure I3: Typical 9-axle B-double (other axle combinations are possible)

B-triples are categorised as road trains (HVNL s5 - definitions) and must comply with prescribed mass and dimension requirements. B-triples sometimes have dedicated networks declared that may be different to road train networks.

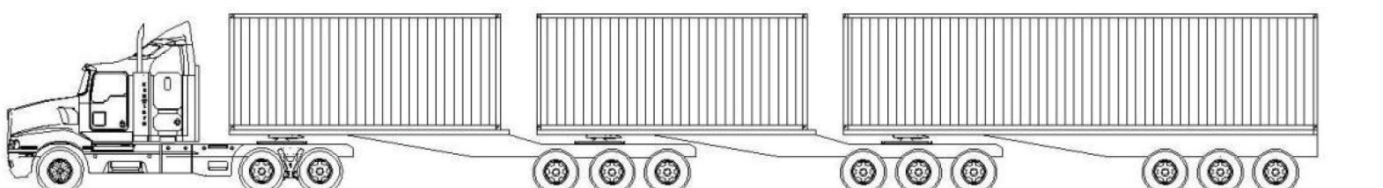

↑Figure I4: 12-axle B-triple

A road train is a class 2 heavy vehicle (HVNL s136 (a) (ii) (B)) that consists of a motor vehicle towing two or more trailers (excluding converter dollies supporting a trailer). Road trains must comply with prescribed mass and dimension requirements.

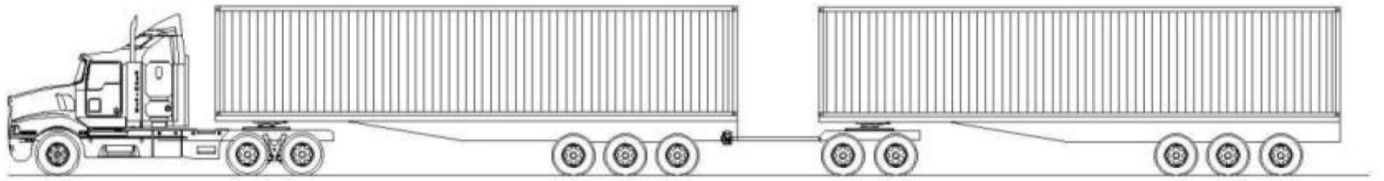

↑Figure I5: A-double (or 'Type I' road train)

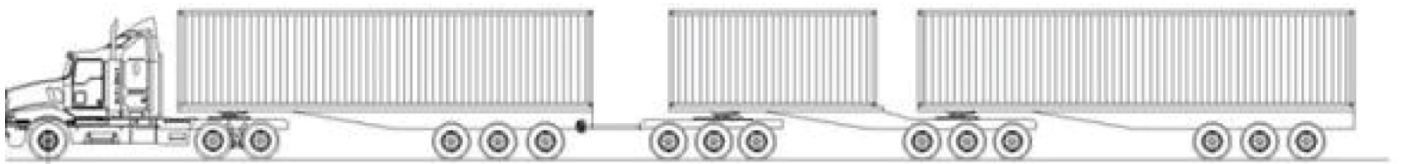

↑Figure I6: AB-triple

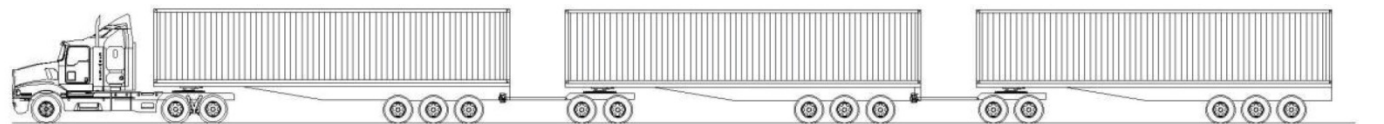

↑Figure I7: A-triple (or 'Type 2' road train)

Buses

A bus, other than an articulated bus, that is longer than 12.5m but less than 14.5m, that complies with prescribed mass and dimension requirements is a class 2 heavy vehicle. These vehicles are also known as a 'Controlled Access Bus' (HVNL s136 (a) (ii) (C)).

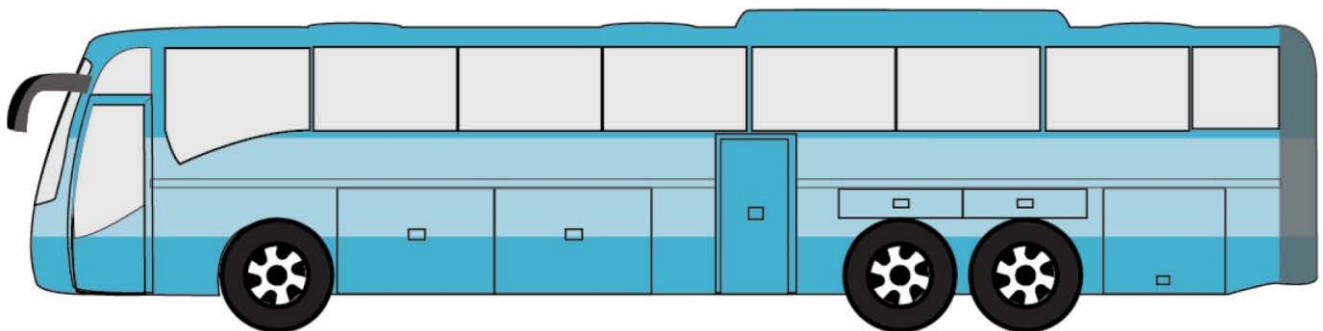

↑Figure I8: Bus longer than 12.5m but less than 14.5m (also known as a 'Controlled Access Bus')

Vehicle carriers

A vehicle carrier is a combination designed and built to carry vehicles on more than one deck that together with its load is longer than 19m or higher than 4.3m (HVNL s136 (a) (ii) (D)).

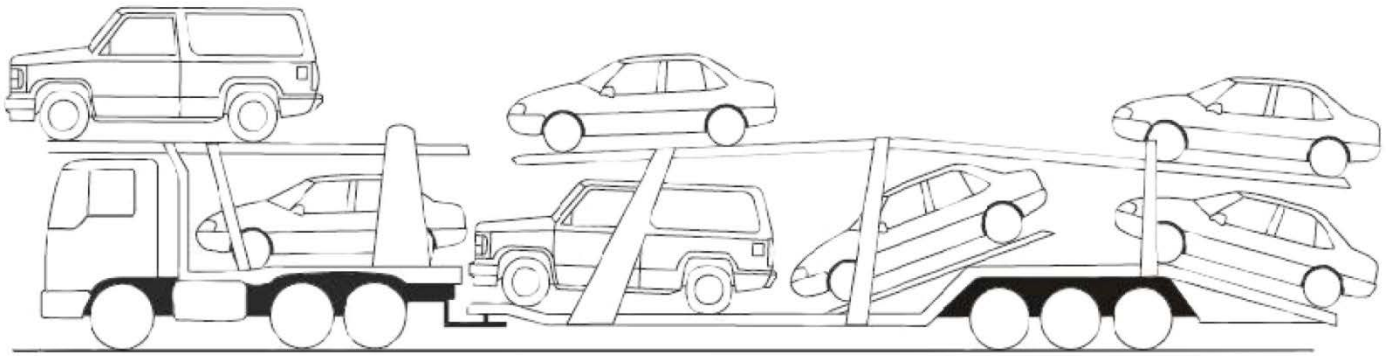

↑Figure 19: Example vehicle carrier (longer than 19m or higher than 4.3m)

Livestock vehicles

A livestock vehicle is a heavy vehicle, or a combination, that is higher than 4.3m and is built to carry cattle, sheep, pigs or horses (HVNL s136 (a) (ii) (E)).

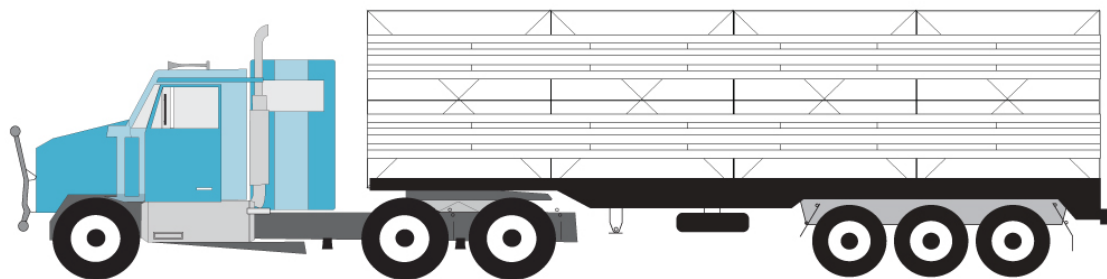

↑Figure 20: Example livestock carrier

Performance-Based Standards (PBS) vehicles

Performance-Based Standards (PBS) vehicles are defined as class 2 heavy vehicles (HVNL s136 (b)). There are four levels within the PBS Scheme, and these vehicles must meet twenty safety and infrastructure standards and are designed to offer higher levels of safety and productivity. PBS vehicles are able to operate on road networks that have been classified as suitable for their level of performance.

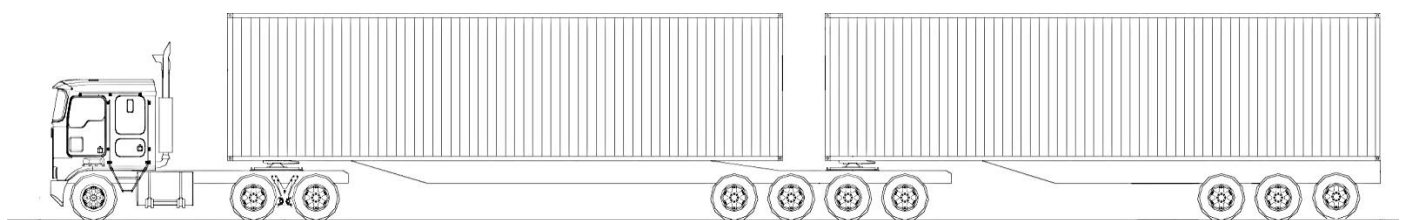

↑Figure 21: Quad tri-axle B-double (Level 2 PBS vehicle)

Class 3 heavy vehicles

A class 3 heavy vehicle is a heavy vehicle which, together with its load, does not comply with prescribed mass or dimension requirements and is not a class 1 heavy vehicle (HVNL s116 (3)). A truck and dog trailer combination consisting of a rigid truck with 3 or 4 axles towing a dog trailer with 3 or 4 axles weighing more than 42.5t is an example of a class 3 heavy vehicle. Other examples might include a B-double or road train transporting a load wider than 2.5m.

Class 3 heavy vehicles do not include PBS vehicles or heavy vehicles complying with prescribed dimension requirements but operating under Concessional Mass Limits (CML) or Higher Mass Limits (HML).

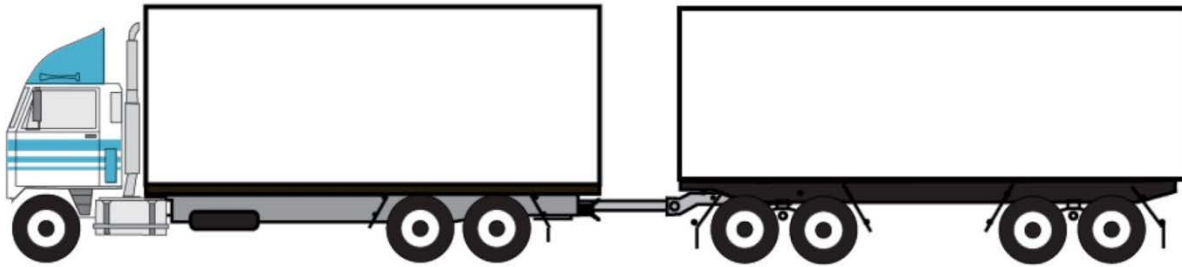

↑Figure 22: Truck and dog trailer combination over 42.5t CCM

About the NHVR

The National Heavy Vehicle Regulator (NHVR) is Australia's dedicated independent regulator for heavy vehicles over 4.5 tonnes gross vehicle mass.

The NHVR was created to administer one set of rules for heavy vehicles under the Heavy Vehicle National Law (HVNL), improve safety and productivity, minimise the compliance burden on the heavy vehicle transport industry and reduce duplication and inconsistencies across state and territory borders.

For more information

- **visit** www.nhvr.gov.au
- **subscribe** www.nhvr.gov.au/subscribe
- **email** info@nhvr.gov.au
- **fax** 07 3309 8777
- **post** PO Box 492, Fortitude Valley Qld 4006
- **phone** 1300 MYNHVR* (1300 696 487)

*Standard 1300 call charges apply.
Please check with your phone provider



© National Heavy Vehicle Regulator (2014)

While every attempt has been made to ensure the accuracy of this fact sheet, it should not be relied upon as legal advice.